

REVISION HISTORY		
REV.	DESCRIPTION	DATE
02	REVISED PER LC1492	2018-04-11
A	INITIAL RELEASE PER LC1492	2018-05-22
B	REVISED PER LC2445	2020-03-23

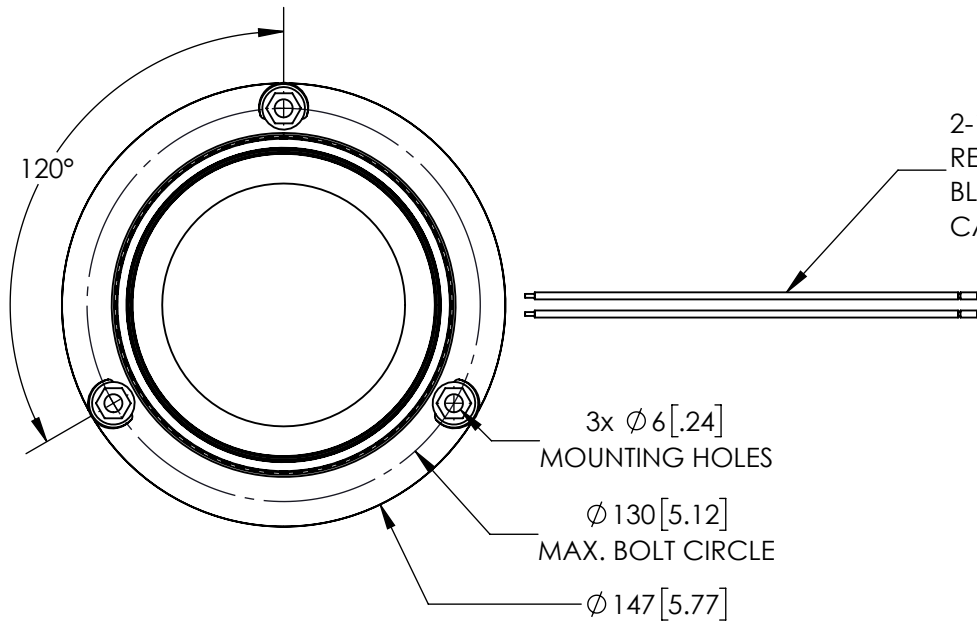

2-18 AWG WIRES
 RED - POSITIVE (+)
 BLACK - NEGATIVE (-)
 CABLE LENGTH - APPROX 300mm

SPECIFICATIONS

- CERTIFICATIONS: ECE R10, ECE R65 APPROVED
 Note: Unique components, accessories and hardware kits are not typically included in the product certification test protocols. Unless otherwise Specified, the product certification referred to herein are predicated Upon the base product model configuration.
- FLASH MODE: DOUBLE FLASH PATTERN (125 FPM)
- VOLTAGE (NOMINAL): 12/24 VDC
- VOLTAGE (EXTREME): 10 to 32 VDC
- CURRENT (RMS): 1.06A (@ 12 VDC NOMINAL)
- CURRENT (PEAK): 1.85A (@ 12 VDC NOMINAL)
- POWER (RMS MAXIMUM): 23W (@ 24 VDC NOMINAL)
- TEMPERATURE RANGE: -20°C (-4°F) TO 50°C (122°F)
- CONNECTION: 18 AWG WIRES IN A CABLE
- MOUNTING: 3 BOLT
- BASE MATERIAL: ASA
- LENS MATERIAL: POLYCARBONATE
- PRODUCT WEIGHT: 0.4KG (0.88lb)

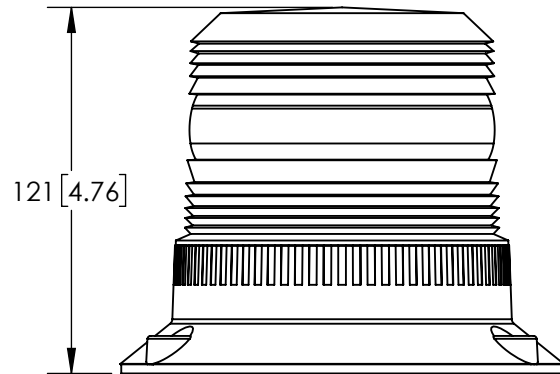

- NOTES:
- DIMENSIONS IN MILLIMETRES [INCHES (FOR REFERENCE)]
 - USE SUB ASSEMBLY (100-EB5014A) FOR MANUFACTURE

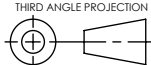
SCALE 1:2.5		APPROVALS	DATE	 ECCO ® www.eccolink.com <small>Americas (800) 635-5900 Europe +44 (0)113 237 5340 Asia Pacific +61 (0)3 63322444</small>
CAD GENERATED DRAWING DO NOT MANUALLY UPDATE. MODEL REFERENCED: A		DRAWN BY: NP	2019-11-27	
TOLERANCES ARE IN INCHES, AND MILLIMETERS TOLERANCES UNLESS OTHERWISE STATED ARE:		CHECKED: LSH	2020-01-06	
MILLIMETERS DECIMALS XX. ± 1.0mm XX.X ± 0.5mm	INCHES DECIMALS X.X ± 0.1 X.XX ± 0.04 X.XXX ± 0.02	MECH. ENG. KW	2019-12-09	
ANGLES ± 0.5°		ELEC. ENG. MMG	2019-11-28	
FRACTIONS ± 1/64		TEST ENG. JUP	2019-12-12	
THIRD ANGLE PROJECTION		SALES.		
		Electronically Controlled Use Latest Copy		
PROPRIETARY AND CONFIDENTIAL INFORMATION <small>THIS DRAWING AND THE DESIGN AND OTHER INFORMATION DISCLOSED HEREIN ARE THE PROPERTY OF ELECTRONIC CONTROLS COMPANY AND/OR ITS ECCO SAFETY GROUP AFFILIATES ("ECCO") AND IS ISSUED IN CONFIDENCE TO RECIPIENT FOR ENGINEERING INFORMATION PURPOSES ONLY. THIS DRAWING AND THE DESIGN AND OTHER INFORMATION DISCLOSED HEREIN MAY NOT BE USED, COPIED, REPRODUCED OR OTHERWISE DISCLOSED IN PART OR IN WHOLE TO THIRD PARTIES OR USED FOR ANY OTHER PURPOSE WITHOUT PRIOR ECCO WRITTEN CONSENT. ECCO RESERVES ALL PATENT, COPYRIGHT, TRADEMARK, AND OTHER PROPRIETARY RIGHTS TO THIS DOCUMENT, INCLUDING ALL DESIGN, MANUFACTURING, REPRODUCTION, USE AND SALES RIGHTS THEREOF. THIS DRAWING IS SUBJECT TO RECALL BY ECCO AT ANY TIME, AND YOUR POSSESSION AND/OR USE CONSTITUTES ACCEPTANCE OF THESE TERMS. ©2019 ELECTRONIC CONTROLS COMPANY</small>		ECCOLED, SILVER, 3 BOLT, R65, AMB, 12/24V CUSTOMER PART NO. EB5014A PRODUCT SERIES: ECCOLED		
SIZE: A4	DWG. NO. EB5014A	SHEET 1 OF 1	Project: LC1492	Date Created: 2018-02-12 REV. B