

| REVISION HISTORY | | |
|------------------|--|------------|
| REV. | DESCRIPTION | DATE |
| C | LATEST BASE VERSION SHOWN AS PER CR VA0119 | 31-Jan-05 |
| D | LABEL 990.315 REMOVED AS PER CR VA0234 | 02-Jun-06 |
| E | UPDATED AS PER CR# 0407 | 2007-11-21 |

NOTES:
 1. DIMENSIONS IN MILLIMETERS (INCHES)
 2. WIRES, CABLES, CONNECTORS AND TIE WRAPS NOT SHOWN.

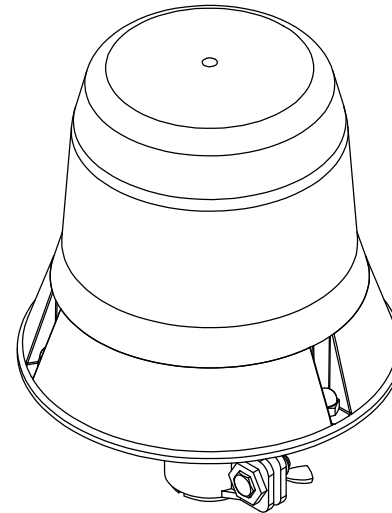
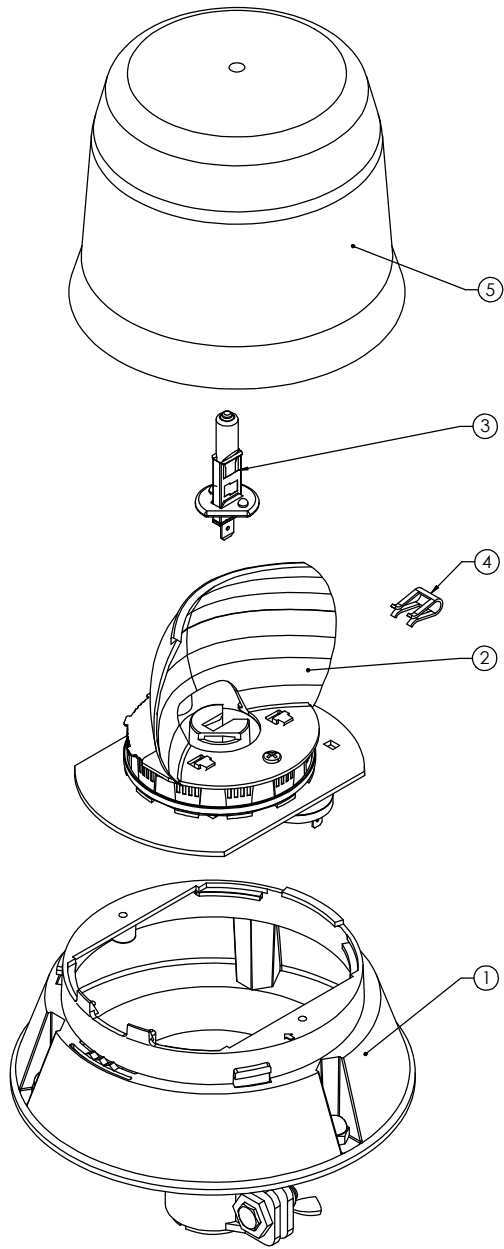

| ITEM NO. | QTY. | PART NO. | DESCRIPTION | COMMENTS |
|----------|------|----------|--|-----------|
| 1 | 1 | 999.025 | BASE, BEACON, POLE MOUNT | |
| 2 | 1 | 999.554 | BEACON ROTATOR MODULE ASSY, 400 SERIES | |
| 3 | 1 | 950.448 | BULB, 1255/H1, 12V | |
| 4 | 1 | 920.004 | BULB CLIP, VA ROTATOR | |
| 5 | 1 | 910.320 | LENS, 400 SERIES BEACON, AMBER, 'E' APPROVED | |
| 6 | 1 | 990.168 | LABEL, BEACON, 400 SERIES, AMBER | NOT SHOWN |
| 7 | 1 | 990.231 | FITTING INSTRUCTION, UNIVERSAL | NOT SHOWN |

| APPROVALS | DATE |
|-----------------|------|
| DESIGNER CJB | |
| CHECKED | |
| APPROVED | |
| | |
| | |

VISION ALERT VISION ALERT AUTOMOTIVE LIMITED
 Victoria Industrial Park, Victoria Road, Seacroft, Leeds LS14 2LA
 Tel: +44 (0)113 237 5340 Fax: +44 (0)113 237 5360
 Email: sales@visionalert.co.uk

BEACON, 400 SERIES, PLUG IN, AMBER, 12V

| | |
|--------------------|-------------------------|
| Project: CR VA0065 | Date Created: 28-May-04 |
| SIZE A3 | PART NO. 402.001 |
| SCALE 1:1 | ECCO PART NO. |
| | REV. E |

NON DISCLOSURE AGREEMENT
 THE DRAWING AND THE DESIGN IT DISCLOSES ARE THE PRIVATE PROPERTY OF VISION ALERT AND IS LOANED IN CONFIDENCE FOR ENGINEERING INFORMATION ONLY. THE DRAWING AND / OR DESIGN MAY NOT BE REPRODUCED, COPIED, REPRODUCED, OR OTHERWISE DISCLOSED IN PART OR AS A WHOLE TO OUTSIDERS OF VISION ALERT WITHOUT THE PRIOR WRITTEN CONSENT OF VISION ALERT. THE DRAWING IS SUBJECT TO RECALL AT ANY TIME. YOUR POSSESSION OF THIS DOCUMENT CONSTITUTES ACCEPTANCE OF THESE TERMS. © 2003 VISION ALERT

CUSTOMER COPY

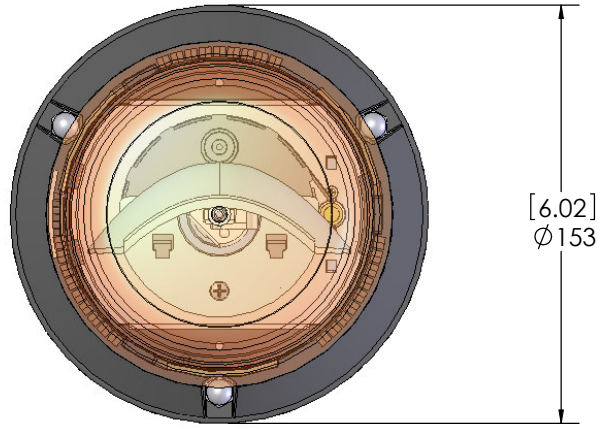

TOP VIEW

[6.02]
Ø153

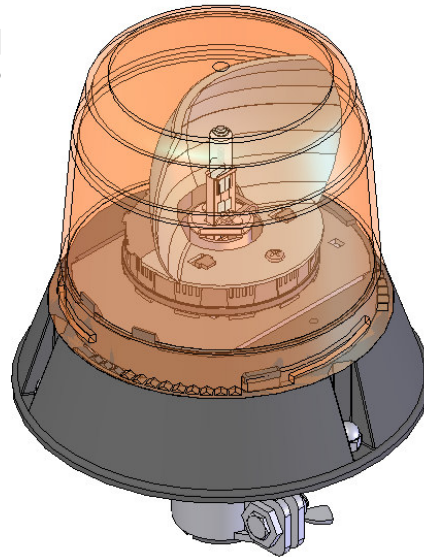

ISOMETRIC VIEW

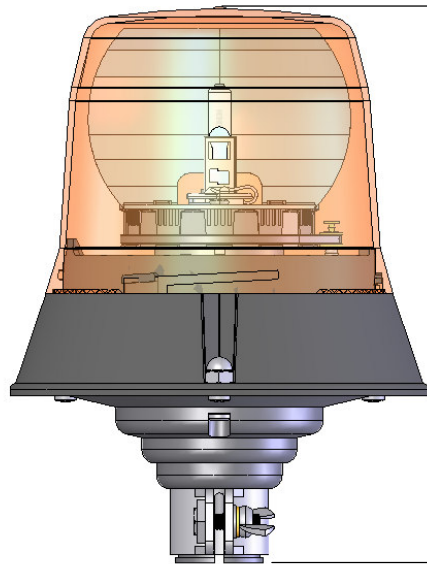

FRONT VIEW

[8.01]
203.5

SPECIFICATIONS

1. CERTIFICATIONS:
EC 95/54
REG 65 'E' APPROVED
2. VOLTAGE: 12V
3. TEMPERATURE RANGE -30°C TO 50°C
4. MOUNTING: PLUG IN
5. BASE MATERIAL: POLYCARBONATE
6. LENS MATERIAL: POLYCARBONATE
7. WEIGHT: 0.8KG APPROX
8. DIMENSIONS IN MILLIMETRES [INCHES]
9. TOTAL CURRENT CONSUMPTION: 4.6 AMPS APPROX
10. FLASH RATE: 160 FLASHES PER MINUTE

VISION ALERT ® VISION ALERT AUTOMOTIVE LIMITED
Victoria Industrial Park, Victoria Road, Seacroft, Leeds LS14 2LA
 Tel: +44 (0)113 237 5340 Fax: +44 (0)113 237 5360
 Email: sales@visionalert.co.uk

BEACON, 400 SERIES, PLUG IN, AMBER, 12V

| | | |
|--------------------|---------------------|-------------------------|
| Project: CR VA0065 | | Date Created: 28-May-04 |
| SIZE A4 | PART NO. 402.001 | ECCO PART NO. |
| SCALE 1:1 | | REV. E |
| | | SHEET 1 of 1 |