

F
E
D
C
B
A

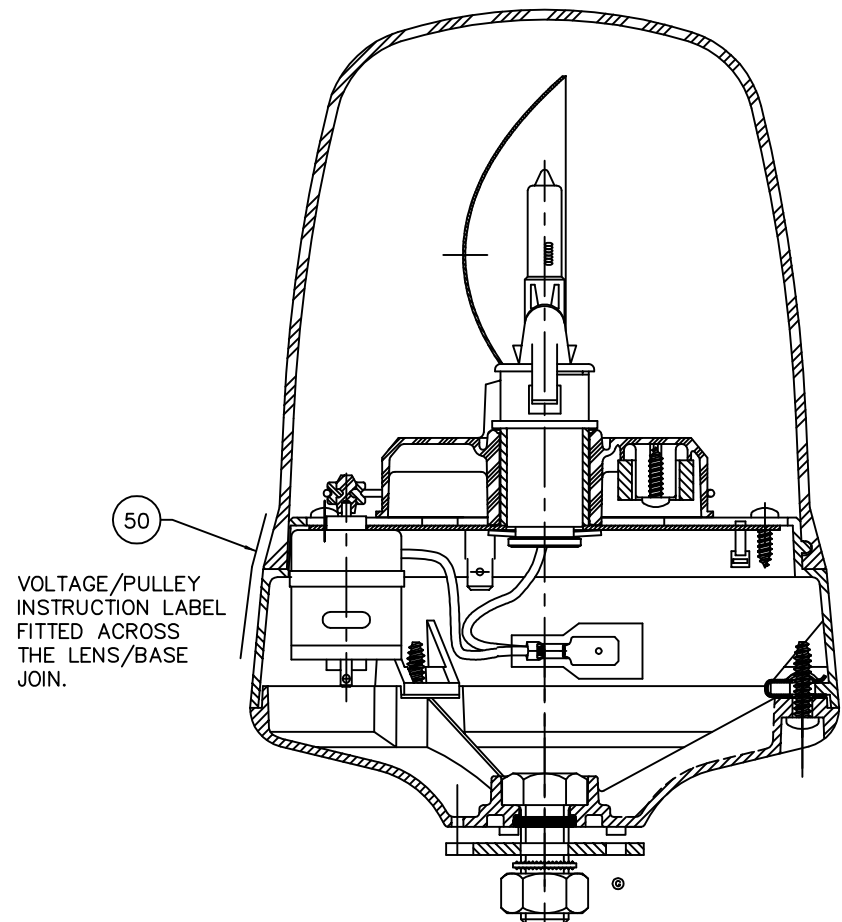

ASSEMBLY TIGHTENING TORQUE 0.65Nm(5.75 lbf in) FOR ALL THREADED FASTENERS

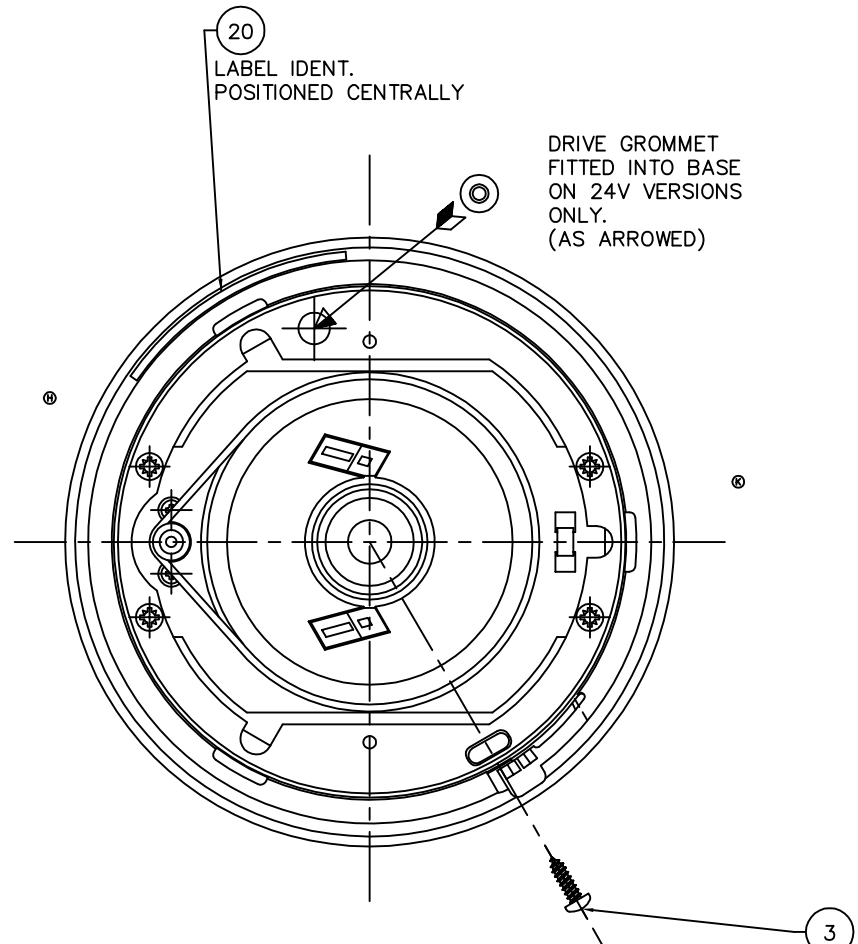
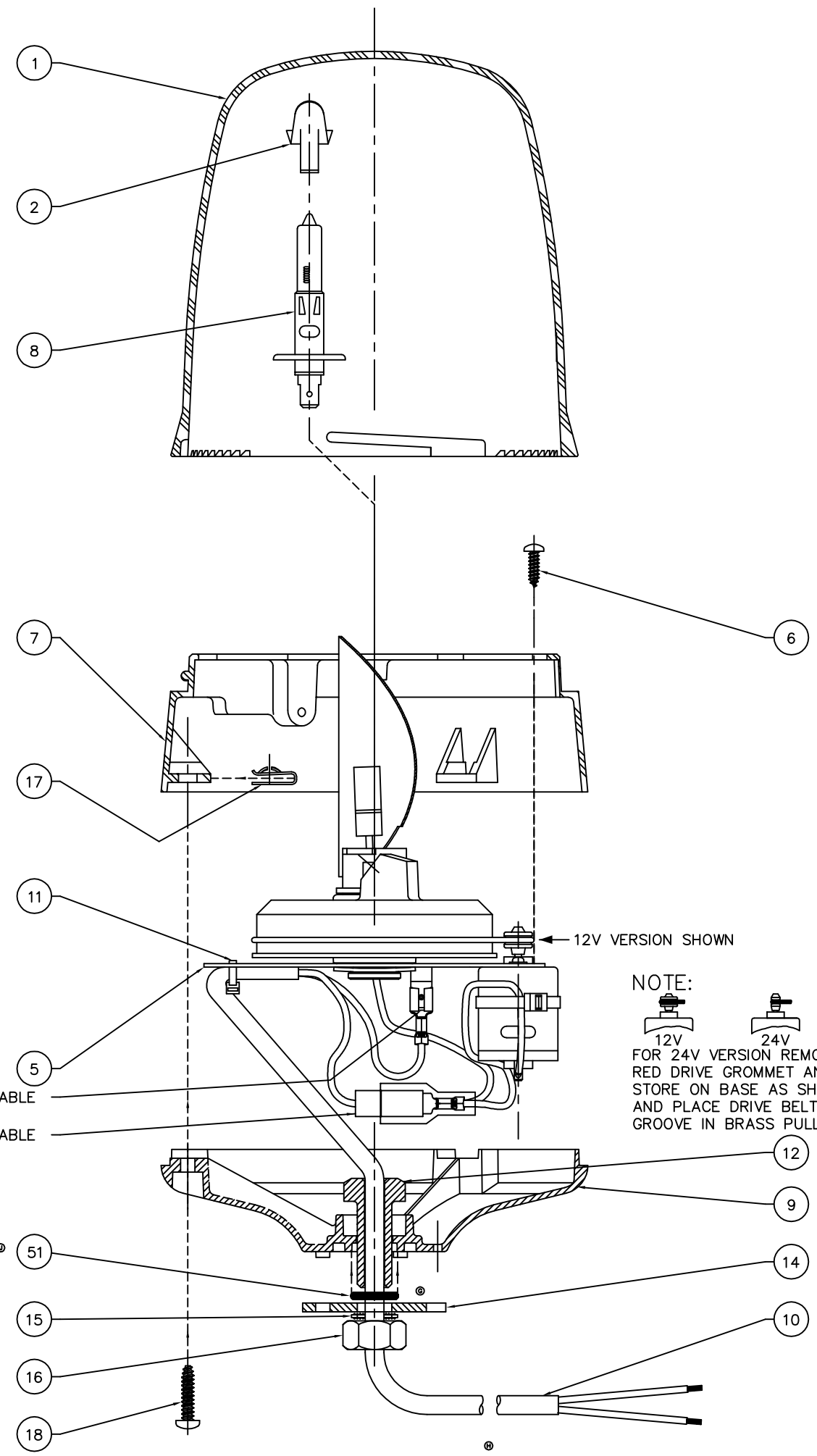

CERTIFICATION PROCEDURE INVOLVED - UNAUTHORISED DEVIATION STRICTLY FORBIDDEN

MOD No	REFERENCE	ISS	DATE	BY
4517	PRE-PROD REL	1	05/05/93	A.S.
4628	PRODUCTION REL	A	12/07/93	R.W.
4701		B	03/09/93	R.W.
4791		C	15/11/93	R.W.
5604		D	18/10/95	M.E.
6656		E	03/07/97	M.E.
8154		F	26/06/98	M.E.
10142		G	09/11/00	R.G.
12078		H	23/07/01	P.A.
18525		J	15/11/05	S.B.
18932		K	28/03/08	AXS

MATERIAL	SPEC		
FINISH	SPEC		
ESTIMATED MASS			
TOOL No.			
DIMENSIONS IN MILLIMETRES DO NOT SCALE IF IN DOUBT - ASK			
DRAWN IN ACCORDANCE WITH BS308			
DIMENSIONAL TOLERANCES :			
3RD ANGLE PROJECTION	METRIC DESIGN		
BRITAX (PMS) LTD BESINGBY INDUSTRIAL ESTATE BRIDLINGTON NORTH HUMBERSIDE YO18 4SJ			
Britax			
DRAWN	DATE	CHECKED	SCALE
A.SHARP	17/09/92	R.W.	1:1
TITLE			
G.A. ROTATING BEACON - 1 BOLT			
PART No.	Sht No		2
A 1	391		of