

REVISION HISTORY		
REV.	DESCRIPTION	DATE
C	REVISE PER VA CR 1716	2015-09-10
D	REVISE PER LC0208	2016-05-06
E	REVISE PER LP0015	2017-04-11

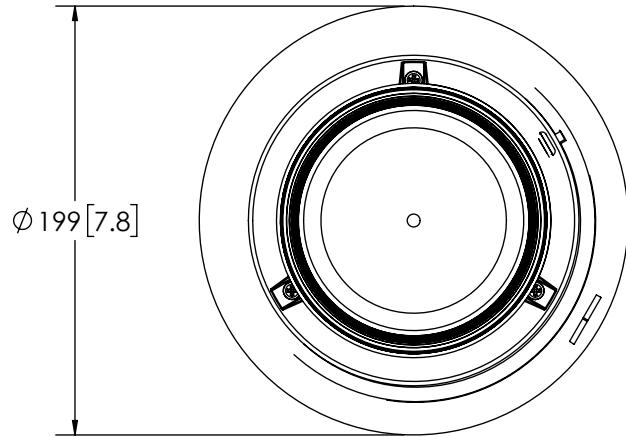

SPECIFICATIONS

- CERTIFICATIONS; R10 & CAP 168 APPROVED
Note: Unique components, accessories and hardware kits are not typically included in the product certification test protocols. Unless otherwise Specified, the product certification referred to herein are predicated upon The base product model configuration.
- FLASH MODE: STATIC FLASH: 60 FLASHES PER MINUTE
- VOLTAGE (NOMINAL): 12/24 VDC
- VOLTAGE (EXTREME): 10 - 30 VDC
- CURRENT (PEAK): 2.0A (@ 12 VDC NOMINAL)
- POWER (MAXIMUM): 24W (@ 12 VDC NOMINAL)
- TEMPERATURE RANGE: -30°C TO 50°C
- CONNECTION: CIGARETTE PLUG
- MOUNTING: MAGNETIC 70 MPH
- BASE MATERIAL: ABS
- LENS MATERIAL: POLYCARBONATE
- PRODUCT WEIGHT: 0.8KG

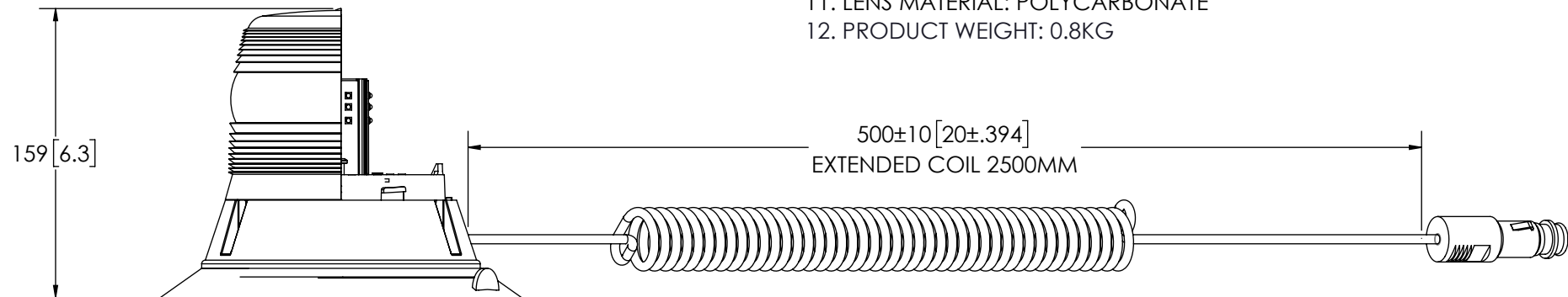

- NOTES:
- DIMENSIONS IN MILLIMETERS [INCHES (FOR REFERENCE)]
 - USE SUB ASSEMBLY (100-V11054.168) FOR MANUFACTURE

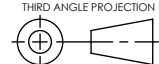
SCALE 1:3.5		APPROVALS	DATE	 www.eccolink.com Americas (800) 635-5900 Europe +44 (0)113 237 5340 Asia Pacific +61 (0)3 63322444
CAD GENERATED DRAWING DO NOT MANUALLY UPDATE. MODEL REFERENCED: D+		DRAWN BY: LSH	2016-09-23	
TOLERANCES ARE IN INCHES, AND MILLIMETERS TOLERANCES UNLESS OTHERWISE STATED ARE:		CHECKED: MDG	2016-10-28	
MILLIMETERS DECIMALS XX. ± 1.0mm XX.X ± 0.5mm	INCHES DECIMALS X.X ± 0.1 X.XX ± 0.04 X.XXX ± 0.02	MECH. ENG.		
		ELEC. ENG. MMG	2016-11-08	
		TEST ENG. DFG	2016-10-28	
		SALES. JSM	2016-10-25	
		BEACON, 400, MAG 70, AMBER, CAP 168, LED CUSTOMER PART NO. V11054.168 PRODUCT SERIES: 400 SERIES		
THIRD ANGLE PROJECTION		SIZE: A4	DWG. NO. VA11054.168	REV. E
		Electronically Controlled Use Latest Copy		SHEET 1 OF 1 Project: LC0208 Date Created: 2015-11-20

NON DISCLOSURE AGREEMENT

THIS DRAWING AND THE DESIGN IT DISCLOSES ARE THE PRIVATE PROPERTY OF ESG AND IS ISSUED IN CONFIDENCE FOR ENGINEERING INFORMATION ONLY. THE DRAWING AND / OR DESIGN MAY NOT BE USED, COPIED, REPRODUCED, OR OTHERWISE DISCLOSED IN PART OR AS A WHOLE TO OUTSIDERS OR USED FOR ANY OTHER PURPOSE WITHOUT THE PRIOR WRITTEN CONSENT OF ESG. THE DRAWING IS SUBJECT TO RECALL AT ANY TIME. YOUR POSSESSION OF THIS DOCUMENT CONSTITUTES ACCEPTANCE OF THESE TERMS. © 2015 ECCO