



DIRECTIONAL



ED3511 SERIES

Surface Mount

The ED3511 LED warning light is designed to offer maximum performance with a minimal footprint. This surface mount LED measures only 0.5" (13mm) deep, features 36 flash patterns and is available in amber or green. Its compact form allows for mounting in virtually any location on a vehicle body, while its twelve 1-watt LEDs provide high-intensity utility and warning lighting. With a low current draw, long maintenance-free service life and a 5-year warranty, the ED3511 Series is a small yet powerful LED for work trucks, recovery vehicles or any other commercial vehicle application.

Models

PART NO.	TYPE	LED COLOUR OPTIONS	AMPS
ED3511X	Single	■ A ■ G	1.4

Replace "X" in part number with desired colour: A=amber, G=green

Design Features

- 12-24 VDC
- Twelve 1-watt high-intensity LEDs provide exceptional warning
- 36 flash patterns
- All electronics embedded in lighthead
- Can be synchronised with additional ED3511s and Hide-A-LEDs
- UV-stabilized polycarbonate lens
- 13" (330mm) cable
- Temperature Range: -22 F to +122 F (-30 C to +50 C)

Dimensions

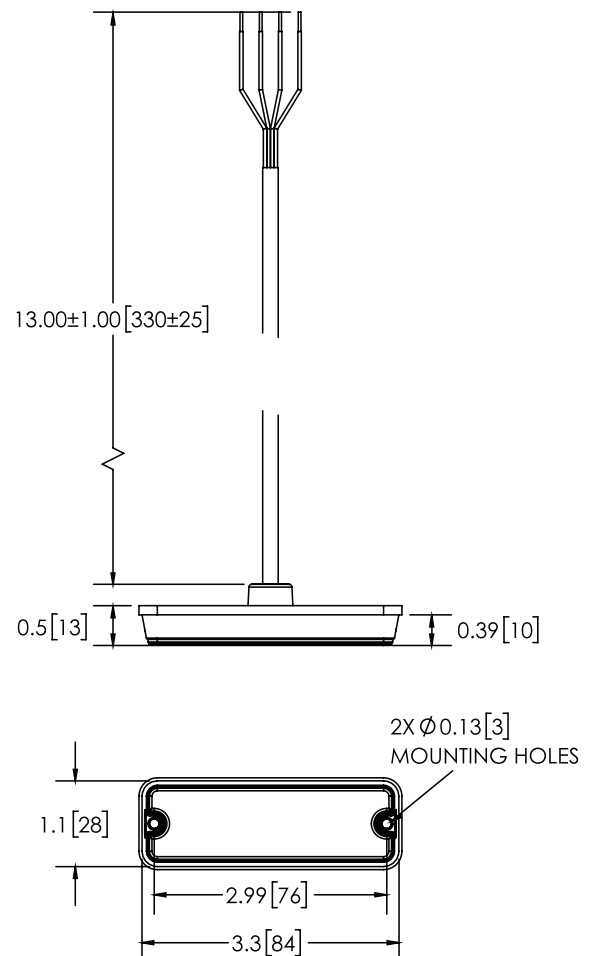

Measurements in inches (millimetres)

+44 (0)113 237 5340 | sales@eccogroup.com