

REVISION HISTORY		
REV.	DESCRIPTION	DATE
03	REVISED PER EP0135	2022-05-25
04	REVISED PER EP0135	2022-06-03
A	INITIAL RELEASE PER EP0135	2022-06-15

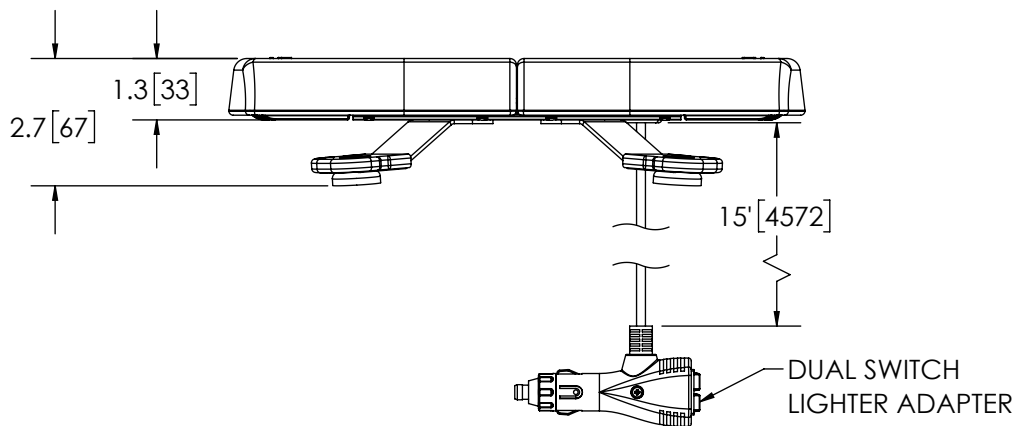
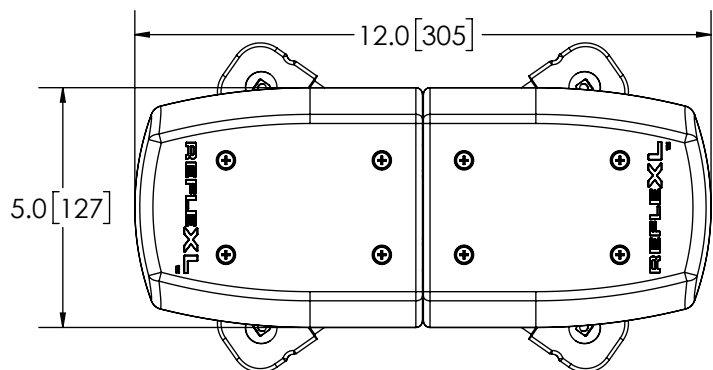

## SPECIFICATIONS

- CERTIFICATIONS: **CE**; ECE R10; AMECA/SAE J845 (FEB 2019) CLASS 1A; YELLOW, WHITE; CA Title 13 CLASS E, AMBER; ; Reg 65 CertE6 TA1 000427; IP69K  
Note: Unique components, accessories, and hardware kits are not typically included in the Product Certification Test Protocols. Unless otherwise Specified, the Product Certifications referred to herein are predicated upon the base product model configuration.
- FLASH MODE: SINGLE : 75 ± 5 FLASHES PER MINUTE  
SINGLE : 120 ± 5 FLASHES PER MINUTE  
DOUBLE : 75 ± 5 FLASHES PER MINUTE
- VOLTAGE (NOMINAL): 12-24 VDC
- VOLTAGE (EXTREME): 9.0-32 VDC
- CURRENT (PEAK): 3.9A (@ 12 VDC NOMINAL)
- POWER (MAXIMUM): 49.4W (@ 12 VDC NOMINAL)
- TEMPERATURE RANGE: -40°F (-40°C) TO 185°F (85°C)
- CONNECTION: 15' CORD W/DUAL SWITCH LIGHTER ADAPTER
- MOUNTING: MAGNET MOUNT
- BASE MATERIAL: ALUMINUM
- LENS MATERIAL: POLYCARBONATE
- PRODUCT WEIGHT: 2.6 LBS (1.17 Kg)

COLOR CHART	
FGS. NO.	COLOR
11-012CAC-E-MG	AMBER/WHITE
11-012CA-E-MG	AMBER
11-012CC-E-MG	WHITE

- NOTES:
- ROHS COMPLIANT
  - DIMENSIONS IN INCHES[MILLIMETERS (FOR REFERENCE)]

PROPRIETARY AND CONFIDENTIAL INFORMATION

THIS DRAWING AND THE DESIGN AND OTHER INFORMATION DISCLOSED HEREIN ARE THE PROPERTY OF ELECTRONIC CONTROLS COMPANY AND/OR ITS ECCO SAFETY GROUP AFFILIATES ("ECCO") AND IS ISSUED IN CONFIDENCE TO RECIPIENT FOR ENGINEERING INFORMATION PURPOSES ONLY. THIS DRAWING AND THE DESIGN AND OTHER INFORMATION DISCLOSED HEREIN MAY NOT BE USED, COPIED, REPRODUCED OR OTHERWISE DISCLOSED IN PART OR IN WHOLE TO THIRD PARTIES OR USED FOR ANY OTHER PURPOSE WITHOUT PRIOR ECCO WRITTEN CONSENT. ECCO RESERVES ALL PATENT, COPYRIGHT, TRADEMARK AND OTHER PROPRIETARY RIGHTS TO THIS DOCUMENT, INCLUDING ALL DESIGN, MANUFACTURING, REPRODUCTION, USE AND SALES RIGHTS THERETO. THIS DRAWING IS SUBJECT TO RECALL BY ECCO AT ANY TIME, AND YOUR POSSESSION AND/OR USE CONSTITUTES ACCEPTANCE OF THESE TERMS. ©2022 ELECTRONIC CONTROLS COMPANY

SCALE 1:4		APPROVALS	DATE
CAD GENERATED DRAWING DO NOT MANUALLY UPDATE.		DRAWN BY BTK	2022-06-03
TOLERANCES ARE IN INCHES, AND MILLIMETERS TOLERANCES UNLESS OTHERWISE STATED ARE:		CHECKED ABD	2022-06-06
MILLIMETERS DECIMALS XX. ± 1.0mm XX.X ± 0.5mm	INCHES DECIMALS X.X ± 0.1 X.XX ± 0.04 X.XXX ± 0.02	MECH. ENG. NMT	2022-06-03
	ANGLES ± 0.5° FRACTIONS ± 1/64	ELEC. ENG. SPO	2022-06-03
		TEST ENG. BMH	2022-06-03
		SALES.	
THIRD ANGLE PROJECTION			



**REFLEX XL,12",CLR LENS,MAG MOUNT**

CUSTOMER PART NO.  
**SEE CHART**

SIZE: A	DWG. NO. 11-012CXX-E-MG	REV. A
Electronically Controlled Use Latest Copy		
SHEET 1 OF 1	Project: EP0135	Date Created: 2022-02-15